

SANITARY SEWER KEYNOTES:

- (S1) INSTALL SEWER MAINTENANCE HOLE ON END OF EXISTING SEWER MAIN PER CITY OF DAVIS STANDARD PLAN 201-2. SEWER MAINTENANCE HOLE SHALL BE ARMOROCK, OR APPROVED EQUAL.
- (S2) INSTALL SEWER PUMP STATION (DESIGN BY OTHERS).
- (S3) INSTALL PRIVATE 2" HDPE DR17 SANITARY SEWER FORCE MAIN (APPROXIMATELY 640 L.F.) BETWEEN PUMP STATION AND MAINTENANCE HOLE, LOCATED 2' BEHIND SIDEWALK. MAINTAIN 36" MINIMUM COVER OVER FORCE MAIN.
- (S4) INSTALL 4" SANITARY SEWER SERVICE TO WITHIN 5' OF BUILDING PER CITY OF DAVIS STANDARD PLAN 201-1. LENGTH AND SLOPE PER PLAN. SEE PLUMBING PLANS FOR 2-WAY CLEANOUT AND CONTINUATION INTO BUILDING. VERIFY LOCATION, SIZE AND DEPTH OF BUILDING SEWER STUB WITH PLUMBING PLANS.
- (S5) INSTALL 4" SANITARY SEWER SERVICE BETWEEN BUILDING AS SHOWN PER CITY OF DAVIS STANDARD PLAN 201-1. SEE BUILDING PLUMBING PLANS FOR CLEANOUTS AND CONTINUATION INTO BUILDINGS. VERIFY LOCATION AND SIZE OF BUILDING SEWER STUBS WITH PLUMBING PLANS.

PROCESS WASTE KEYNOTES:

- (P1) INSTALL SEWER MAINTENANCE HOLE FOR USE AS A SAMPLING STATION PER CITY OF DAVIS STANDARD PLAN 201-2. SEWER MAINTENANCE HOLE SHALL BE ARMOROCK, OR APPROVED EQUAL.
- (P2) JOIN SAMPLING MANHOLE TO SEWER PUMP STATION WITH 4" SEWER PIPE AS SHOWN.
- (P3) INSTALL 4" PROCESS WASTE SERVICE TO WITHIN 5' OF BUILDING PER CITY OF DAVIS STANDARD PLAN 201-1. LENGTH AND SLOPE PER PLAN. SEE PLUMBING PLANS FOR 2-WAY CLEANOUT AND CONTINUATION INTO BUILDING. VERIFY LOCATION, SIZE AND DEPTH OF BUILDING SEWER STUB WITH PLUMBING PLANS. VERIFY LOCATION AND SIZE OF BUILDING PROCESS WASTE WITH PLUMBING PLANS.

IRRIGATION WATER KEYNOTES:

- (I1) INSTALL 2" IRRIGATION SERVICE WITH 2" METER AND 2" REDUCED PRESSURE BACKFLOW ASSEMBLY PER CITY OF DAVIS STANDARD PLAN 101-11. SEE LANDSCAPE IRRIGATION PLANS FOR CONTINUATION.

DOMESTIC WATER KEYNOTES:

- (W1) LOCATE AND EXTENT EXISTING 8" WATER SERVICE STUB TO SITE AS SHOWN (APPROXIMATELY 15 L.F.).
- (W2) INSTALL 4" DOMESTIC WATER SERVICE WITH 4" GATE VALVE, 4" METER AND 4" REDUCED PRESSURE BACKFLOW ASSEMBLY PER CITY OF DAVIS STANDARD PLAN 101-11.
- (W3) INSTALL 4" DOMESTIC WATER SERVICE TO WITHIN 5' OF BUILDING PER CITY OF DAVIS STANDARD PLAN 201-1. SEE BUILDING PLUMBING PLANS FOR SHUT-OFF VALVE AND CONTINUATION INTO BUILDING. VERIFY LOCATION AND SIZE OF BUILDING DOMESTIC WATER STUB WITH PLUMBING PLANS.
- (W4) PROPOSED WATER CROSSING WITH OTHER UTILITY AS SHOWN ON PLAN - SEE UTILITY NOTE 7 BELOW.
- (W5) INSTALL 1" DOMESTIC WATER SERVICE BETWEEN BUILDING AS SHOWN PER CITY OF DAVIS STANDARD PLAN 201-1. SEE BUILDING PLUMBING PLANS FOR SHUT-OFF VALVE AND CONTINUATION INTO BUILDING. VERIFY LOCATION AND SIZE OF BUILDING DOMESTIC WATER STUB WITH PLUMBING PLANS.

FIRE WATER KEYNOTES:

- (F1) INSTALL 8" X 6" REDUCER AND 6" FIRE SPRINKLER SERVICE WITH 6" DOUBLE CHECK DETECTOR CHECK ASSEMBLY (AMES 3000SS) (WITH INTEGRATED FIRE DEPARTMENT CONNECTION) PER CITY OF DAVIS STANDARD PLAN 101-9.
- (F2) INSTALL 6" FIRE SPRINKLER SERVICE TO WITHIN 5' OF BUILDING PER CITY OF DAVIS STANDARD PLANS 101-2 AND 201-1. SEE BUILDING FIRE PROTECTION PLANS FOR FIRE RISER WITHIN BUILDING. VERIFY LOCATION AND SIZE OF BUILDING FIRE SPRINKLER STUB WITH FIRE PROTECTION PLANS.

STORM DRAIN KEYNOTES:

- (D1) INSTALL STORM DRAIN MAINTENANCE HOLE ON END OF EXISTING STORM DRAIN SERVICE LATERAL PER CITY OF DAVIS STANDARD PLAN 201-2. JOIN NEW SITE STORM DRAIN PIPE TO NEW STORM DRAIN MAINTENANCE HOLE AS SHOWN.
- (D2) INSTALL SITE STORM DRAIN MAIN PER CITY OF DAVIS STANDARD PLAN 201-1.
- (D3) INSTALL PRE-CAST CONCRETE DRAIN INLET (CENTRAL PRECAST OR APPROVED EQUAL).
- (D4) DAYLIGHT DRAIN PIPE INTO BOTTOM OF BIO-RETENTION PLANTER.
- (D5) INSTALL DROP INLET PER CITY OF DAVIS STANDARD PLAN 401-1.

UTILITY NOTES

1. SEE LANDSCAPE PLANS FOR IRRIGATION SLEEVE LOCATIONS.
2. SEE ELECTRICAL PLANS FOR SITE ELECTRICAL, LIGHTING AND TELECOMMUNICATIONS.
3. WATER PIPES TO BE INSTALLED WITH 36" MINIMUM COVER AND 12" MINIMUM SEPARATION FROM OTHER UTILITIES (INCLUDING OTHER WATER LINES) - SEE CROSSING DETAIL HEREON. SITE WATER PIPES SHALL EITHER BE MECHANICALLY RESTRAINED AT ALL JOINTS AND FITTINGS OR HAVE CONCRETE THRUST BLOCKS INSTALL AT ALL FITTINGS PER CITY OF DAVIS STANDARD PLAN 101-2.
4. ALL UTILITY PIPE TRENCHES ARE TO BE PER CITY OF DAVIS STANDARD PLAN 201-1.
5. CONTRACTOR TO POTHOLE EXISTING JOINT TRENCH UTILITIES (GAS, ELEC, TELE.) AT EACH PROPOSED UTILITY CROSSING PRIOR TO START OF CONSTRUCTION AND REPORT ANY CONFLICTS TO THE ENGINEER.
6. ALL FIRE WATER PIPE RESTRAINTS DOWNSTREAM OF THE BACKFLOW ASSEMBLY SHALL BE IN CONFORMANCE WITH THE LATEST EDITION OF THE NFPA.
7. PROPOSED GRAVITY UTILITY LINES AND EXISTING UTILITIES SHALL GOVERN VERTICAL INSTALLATION OF PROPOSED WATER IMPROVEMENTS. CONTRACTOR SHALL RAISE/LOWER NEW WATER LINE IMPROVEMENTS TO AVOID VERTICAL CONFLICTS WITH PROPOSED GRAVITY LINES AND EXISTING UTILITIES AT NO COST TO OWNER.
8. ALL FIRE WATER LINES SHALL MAINTAIN 36" MINIMUM COVER PER NFPA.
9. ALL UNDERGROUND FIRE MAINS SHALL BE INSTALLED AND TESTED PER NFPA 24, PRIVATE FIRE SERVICE MAINS AND THEIR APPURTENANCES.
10. ALL CONTROL VALVES ON THE FIRE UNDERGROUND SYSTEM (INCLUDING THE BACKFLOW PREVENTER) SHALL HAVE TAMPER SWITCHES THAT ARE MONITORED BY AN APPROVED FIRE ALARM CENTRAL STATION. CONTRACTOR SHALL PROVIDE THE NECESSARY UNDERGROUND CONDUIT AND COORDINATE THE INSTALLATION WITH THE LOCATION OF THE FIRE ALARM PANEL SUCH THAT VALVES ARE MONITORED PRIOR TO OCCUPANCY.
11. UTILITY SIZES SHOWN HEREON ARE APPROXIMATE AND MAY CHANGE DURING THE DESIGN PROCESS.

DATE SIGNED: _____
 THESE DRAWINGS ARE NOT CONSIDERED FINAL UNTIL THE ENGINEER'S SEAL BELOW HAS BEEN SIGNED AND DATED.

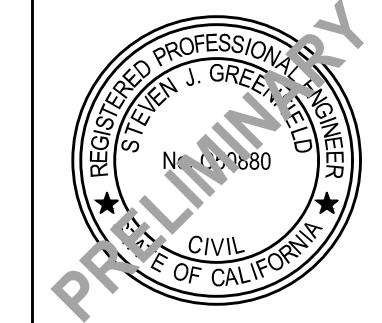

DESIGNED BY	RT	DRAWN BY	RT	CHECKED BY	SG	SCALE	1" = 20'
APPROVED		BY		REVISIONS			
NO.	DATE						

PALISADES, LLC
 4630 FERMI PLACE

PRELIMINARY SITE UTILITY PLAN
 CALIFORNIA

SHEET	01
OF	5
DATE:	03/10/2026
JOB NO:	2094.00.04

S:\Projects\2024\2094_4630_Fermi_Place_Davis\AutoCAD\2094-00-04-DD\SHEETS\2094-00-04-C1-UTIL.dwg - C1_3/10/2026 - 10:24AM Plotted by: Robb

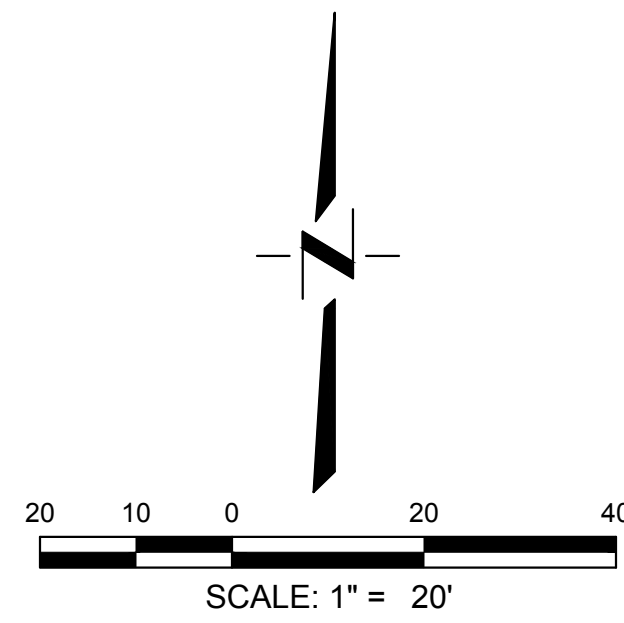

GRADING KEYNOTES:

- (G1) BUILDING PAD SHALL BE CONSTRUCTED TO A MINIMUM OF 5' BEYOND BUILDING WALL LINES OR TO THE OUTER EDGES OF ADJACENT EXTERIOR FLATWORK, WHICHEVER IS GREATER. SEE SOILS REPORT FOR SPECIFIC EARTHWORK GUIDELINES AND RECOMMENDATIONS.
- (G2) PROVIDE FILL SLOPE (2:1 MAXIMUM).
- (G3) CONSTRUCT BIO-RETENTION PLANTER PER DETAIL HEREON.
- (G4) CONSTRUCT RETAINING WALL (DESIGN BY OTHERS).
- (G5) RESTORE STOCKPILE AREA (OUTSIDE OF PROPERTY) TO ORIGINAL GRADES.

GRADING NOTES

1. PROPOSED ELEVATIONS SHOWN ARE FINISH SURFACE UNLESS OTHERWISE NOTED. ELEVATIONS SHOWN AT CURBS REPRESENT FINISHED GRADE AT TOP OF PAVEMENT AT FACE OF CURB OR GUTTER FLOWLINE.
2. FINISH GRADE ADJACENT TO BUILDINGS (WHEN ADJACENT TO LANDSCAPE AREAS AND NO CONCRETE MAINTENANCE STRIP) SHALL BE SET 8" BELOW FINISH FLOOR GRADE.
3. SEE SHEET C4 FOR PAVEMENT SECTION INFORMATION.

BIO-RETENTION PLANTER NOTES:

1. **BIO-TREATMENT SOIL MIX:** THE PLANTING MEDIUM MUST SUSTAIN A MINIMUM INFILTRATION RATE OF 5 INCHES PER HOUR THROUGHOUT THE LIFE OF THE PROJECT AND MUST MAXIMIZE RUNOFF RETENTION AND POLLUTANT REMOVAL. A MIXTURE OF SAND (60%-70%) AND COMPOST (30%-40%) SHALL BE USED. SAND SHALL MEET THE SPECIFICATIONS OF AMERICAN SOCIETY FOR TESTING AND MATERIALS (ASTM) C33. COMPOST SHALL BE A WELL DECOMPOSED, STABLE, WEED FREE ORGANIC MATTER SOURCE DERIVED FROM WASTE MATERIALS INCLUDING YARD DEBRIS, WOOD WASTES OR OTHER ORGANIC MATERIALS NOT INCLUDING MANURE OR BIO-SOLIDS MEETING THE STANDARDS DEVELOPED BY THE US COMPOSTING COUNCIL (USCC). THE PRODUCT SHALL BE CERTIFIED THROUGH THE USCC SEAL OF TESTING ASSURANCE (STA) PROGRAM (A COMPOST TESTING AND INFORMATION DISCLOSURE PROGRAM).
2. MULCH IN BIO-RETENTION AREAS SHALL BE 3" DEPTH OF ORGANIC COMPOST MULCH. OTHER TYPES OF MULCH ARE NOT PERMITTED UNDER THE WATERLINE OR IN THE FREEBOARD AND MUST BE RETAINED BY BENDER BOARD, COBBLE, CONCRETE BARRIER, VEGETATION OR THE LIKE.
3. PLACE NON-WOVEN FILTER FABRIC BETWEEN SOIL AND ROCK LAYERS.
4. MAINTAIN BOTTOM SURFACE ELEVATION OF PLANTER INDICATED HEREON THROUGHOUT BIO-RETENTION PLANTER AREA.
5. THE CLASS 2 PERMEABLE LAYER MAY EXTEND BELOW AND UNDERNEATH DROP INLET.
6. SUBGRADE WITHIN BOTTOM OF STORMWATER PLANTER AREAS (AREAS BENEATH GRAVEL LAYER) SHALL CONSIST OF UNCOMPACTED NATIVE SOIL, RIPPED TO LOOSEN.
7. BIO-RETENTION BASIN TO BE LANDSCAPED PER LANDSCAPE PLANS TO BE SUBMITTED WITH FINAL BUILDING PERMIT PLANS.
8. PROVIDE 24" WIDE AND THICK BORDER OF 4"-6" COBBLES AROUND OVERFLOW OUTLET.
9. BOTTOM AND SIDES OF PLANTER SHALL BE LINED WITH A NON-WOVEN FILTER FABRIC.

FLAT POND BOTTOM ELEVATION (BOT.) PER PLAN, APPROXIMATE BOTTOM LOCATION SHOWN ON PLAN, ACTUAL LOCATION TO BE DETERMINED IN FIELD BY RUNNING 3:1 SLOPE FROM TOP OF PLANTER TO BOTTOM ELEVATION

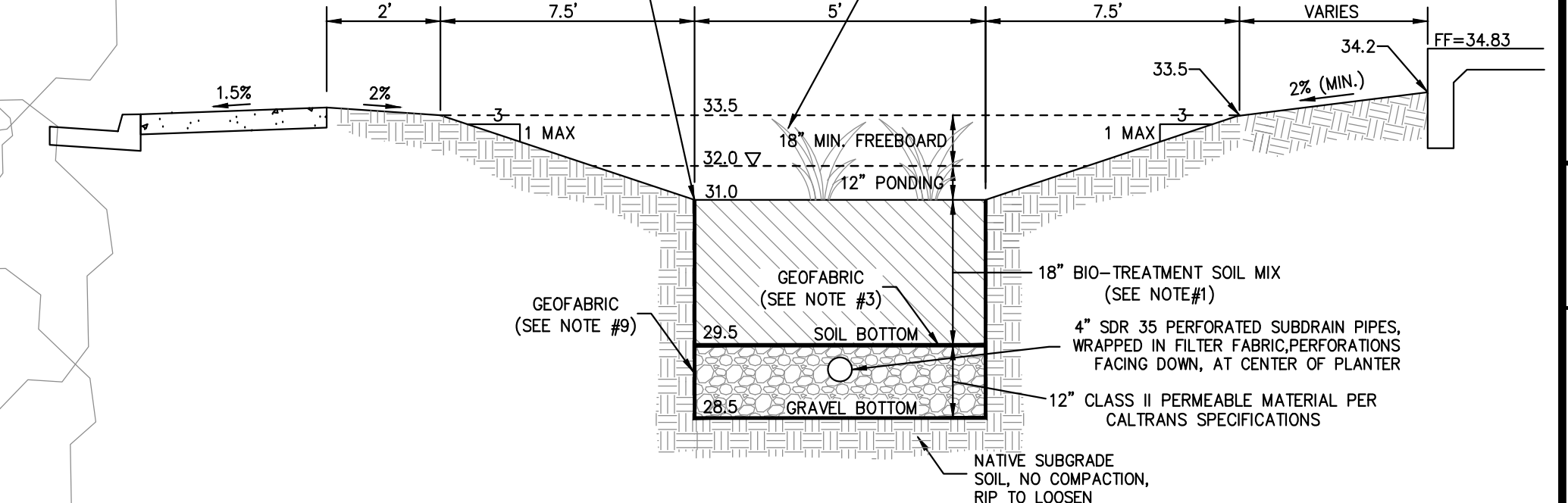

BIO-RETENTION PLANTER - CROSS SECTION
N.T.S.

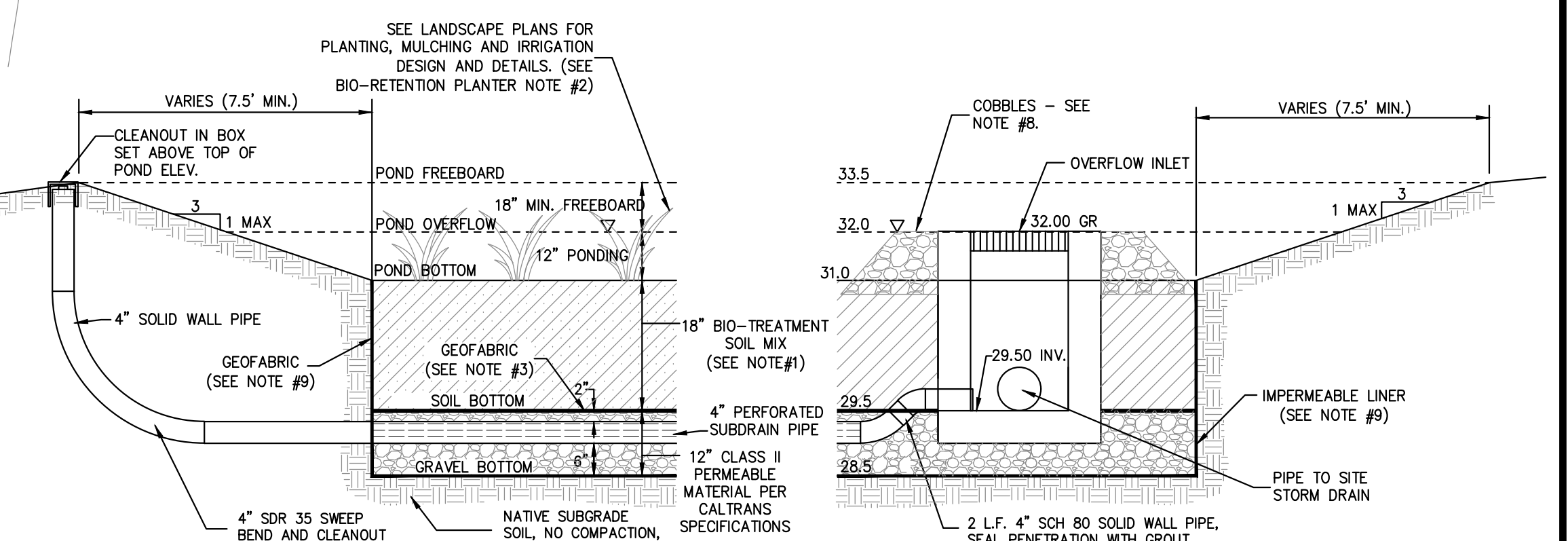

BIO-RETENTION PLANTER - LONGITUDINAL SECTION
N.T.S.

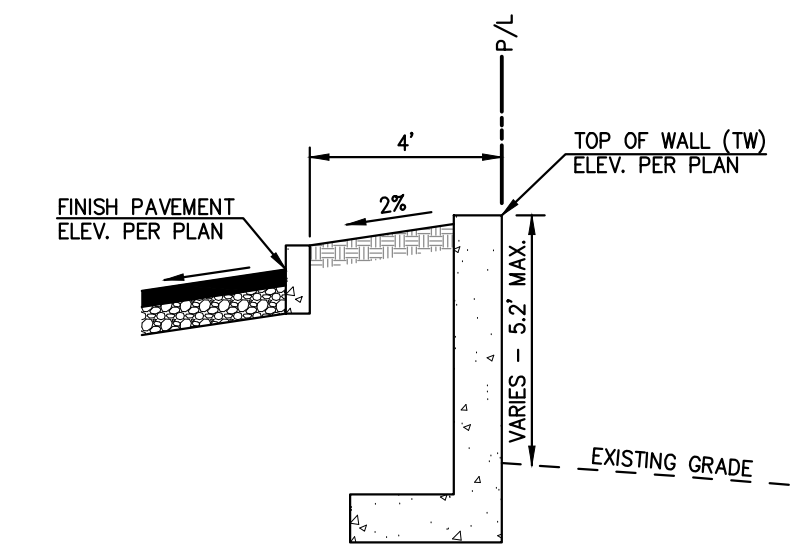

RETAINING WALL
N.T.S.

DATE SIGNED:
THESE DRAWINGS ARE NOT
CONSIDERED FINAL UNTIL THE
ENGINEER'S SEAL BELOW HAS
BEEN SIGNED AND DATED.



DESIGNED BY	RT	DRAWN BY	RT	CHECKED BY	SG	SCALE	1" = 20'
APPROVED		BY		REVISIONS			
NO.	DATE						

PALISADES, LLC
4630 FERMI PLACE

CECWEST.COM
Project Planning = Civil Engineering = Landscape Architecture
Davis Office
2120 20th Street, Suite Three
Sacramento, CA 95818
(916) 455-2026

PRELIMINARY GRADING PLAN

CALIFORNIA

SHEET
C2
OF
5

DATE: 03/10/2026
JOB NO: 2094.00.04

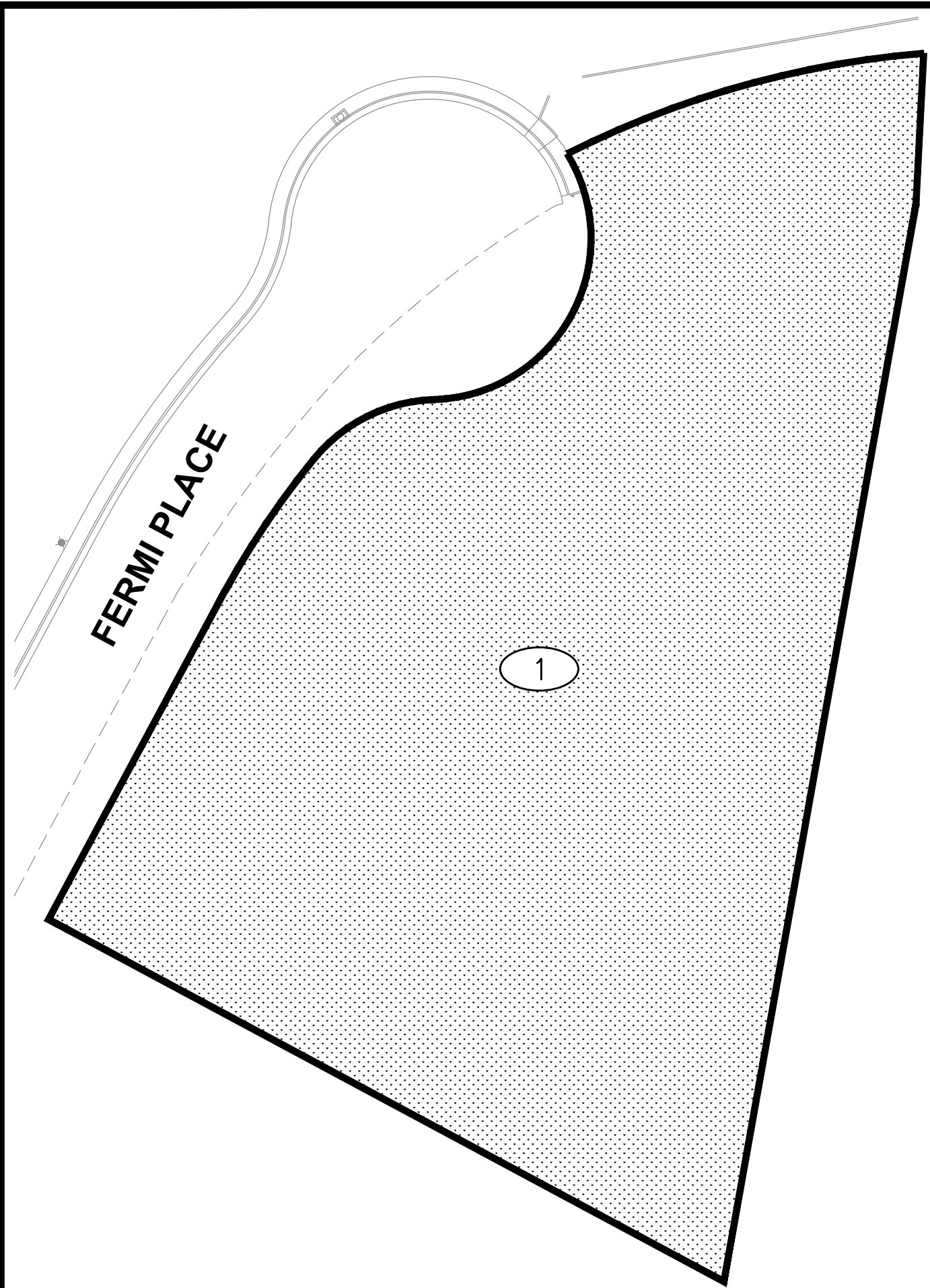

SITE PLAN - EXISTING CONDITION

1" = 40'

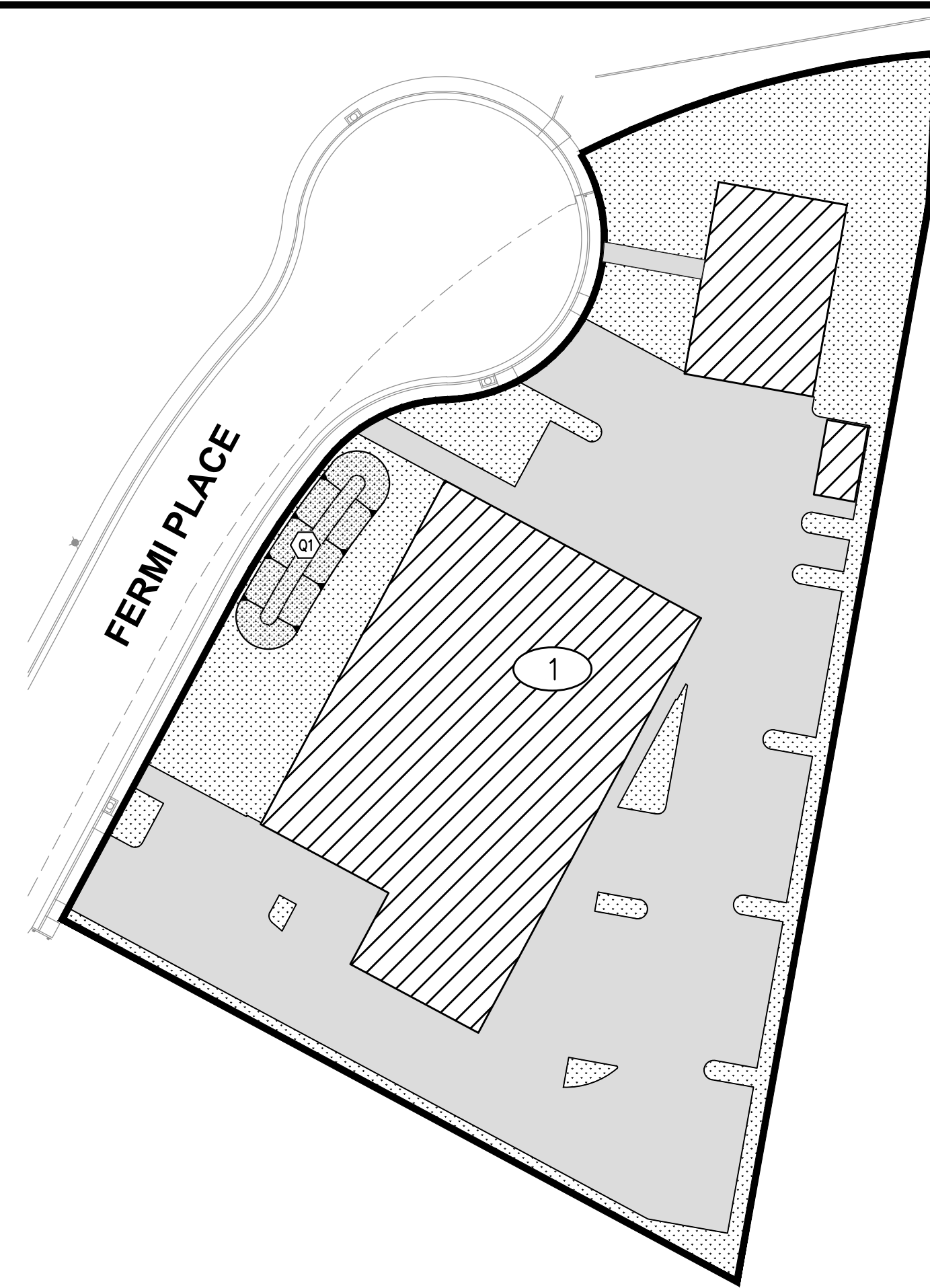

SITE PLAN - PROPOSED CONDITION

1" = 40'

EXISTING AREA SUMMARY:

EXISTING SHED AREA SUMMARY (SF)					
DMA NO.	BLDG. IMPERV. AREA	NON-BLDG. IMPERV. AREA	TOTAL IMPERV. AREA	PERV. AREA	TOTAL AREA
1	0	0	0	54,809	54,809
TOTAL	0	0	0	54,809	54,809

PROPOSED AREA SUMMARY:

PROPOSED SHED AREA SUMMARY (SF)								
DMA NO.	BLDG. IMPERV. AREA	NON-BLDG. IMPERV. AREA	TOTAL IMPERV. AREA	PERV. AREA	TOTAL AREA	EX. TREE AREA	PR. TREES #	PERV. PAVE. AREA
1	14,733	24,102	38,835	15,974	54,809	0	29	0
TOTAL	14,733	24,102	38,835	15,974	54,809	0	29	0

LEGEND:

- DMA/SHED BOUNDARIES
- DMA/SHED NUMBERS
- NON-BUILDING IMPERVIOUS AREAS
- PERVIOUS AREAS
- BUILDING IMPERVIOUS AREAS

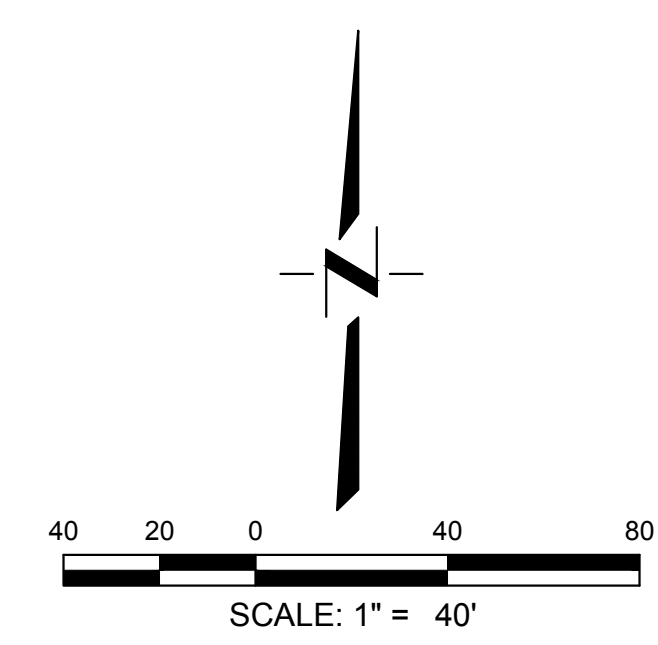

BIO-RETENTION PLANTER SIZING CALCULATIONS

Shed No.	BIO-RETENTION PLANTER CHARACTERISTICS						Bio-retention Volume Required (CF)
	Planter Bottom Area (SF)	Planter Bottom Perimeter (FT)	Planter Pounding Depth (FT)	Bio-soil Mix Depth (FT)	Permeable Material Depth (FT)	Bio-retention Volume Provided (CF)	
1	268	115	1.00	1.50	1.00	668	644
2							
3							
4							
5							
6							
7							
8							
Total						668	644

ASSUMPTIONS

Side slope = 3.00
 Soil pores = 0.30
 Gravel pores = 0.40
 Soil Class = C
 (calculations assume bio-soil and gravel below bottom only, not under side slopes)

PROJECT INFORMATION:

PROJECT NAME: STRATOS LASER
 ADDRESS: 4630 FERMI PLACE
 APPLICANT: HARRISON CONSTRUCTION
 APN#: 071-425-001-000

PROJECT NARRATIVE:

STORMWATER RUNOFF FROM THE COMMERCIAL BUILDINGS WILL BE PIPED INTO THE BIO-RETENTION PLANTERS LOCATED IN THE FRONT OF THE LOT. STORMWATER RUNOFF FROM THE PARKING LOT WILL SHEET FLOW DIRECTLY INTO BIO-RETENTION PLANTERS LOCATED AT THE FRONT OF THE LOT. TREATED STORMWATER FROM THE BIO-RETENTION PLANTERS WILL BE RELEASED INTO THE CITY STORM DRAINAGE SYSTEM IN THE STREET.

SITE DESIGN & RUNOFF REDUCTION MEASURES:

TREE PLANTING AND PRESERVATION
 INTERCEPTOR TREES WILL BE PLANTED THROUGHOUT THE SITE. SEE LANDSCAPE PLANTING PLAN.

POST-CONSTRUCTION STORMWATER KEYNOTES:

POST-CONSTRUCTION STORMWATER TREATMENT WILL BE PROVIDED BY BIO-RETENTION PLANTERS AS SHOWN.

STATEMENT OF COMPLIANCE

STORM WATER QUALITY TREATMENT PERFORMANCE REQUIREMENTS HAVE BEEN MET ON-SITE PER E.12 REQUIREMENTS.

STATEMENT OF HYDROMODIFICATION COMPLIANCE

THIS PROJECT DOES NOT CREATE AND/OR REPLACE ONE ACRE OR MORE OF IMPERVIOUS SURFACE AND THEREFORE IS NOT SUBJECT TO HYDROMODIFICATION MANAGEMENT (PER SECTION E.12.f.(i) OF THE GENERAL PERMIT).

STORMWATER QUALITY KEYNOTES:

INSTALL BIO-RETENTION PLANTER PER DETAIL ON SHEET C2 SITE GRADING PLAN.

POST-CONSTRUCTION WATER BALANCE CALCULATOR - DMA 1

Post-Construction Water Balance Calculator									
User may make changes from any cell that is orange or brown in color (similar to the cells to the immediate right). Cells in green are calculated for you.		(Step 1a) If you know the 85th percentile storm event for your location enter it in the box below.		(Step 1b) If you cannot answer 'a' then select the county where the project is located (click on the cell to the right for drop-down). This will determine the average 85th percentile 24 hr. storm event for your site, which will appear under precipitation to left.		YOLO			
		(Step 1c) If you would like a more precise value select the location closest to your site. If you do not recognize any of these locations, leave this drop-down menu at location. The average value for the County will be used.		DAVIS 2 WSW EXP FARM					
Project Information				Runoff Calculations					
Project Name:		Stratos Laser		(Step 2) Indicate the Soil Type (dropdown menu to right):		Group C Soils		Low Infiltration. Sandy clay loam. Infiltration rate 0.05 to 0.15 inch/hr when wet.	
Waste Discharge Identification (WQID):				(Step 3) Indicate the existing dominant non-built land Use Type (dropdown menu to right):		Open Space: grass cover >75%			
Date:		2026-03-10		(Step 4) Indicate the proposed dominant non-built land Use Type (dropdown menu to right):		A mix of lawn, grass, pasture and trees covering more than 75% of the open space			
Sub Drainage Area Name (from map):		DMA 1		Complete Either		Sg Ft		Acres	
Existing Runoff Curve Number		74		(Step 5) Total Project Site Area		54809		0.00	
Proposed Development Runoff Curve Number		90		(Step 6) Sub-watershed Area		54809		0.00	
Design Storm				Percent of total project		100%			
Based on the County you indicated above, we have included the 85 percentile average 24 hr event - P85 (in) for your area.		0.65		In					
The amount of rainfall needed for runoff to occur (Existing runoff curve number is from existing RCU (in))		0.71		In					
P used for calculations (in) (the greater of the above two criteria)		0.71		In					
Available at: www.cdmuhandbooks.com				(Step 7) Sub-watershed Conditions		Complete Either		Calculated Acres	
				Sub-watershed Area (acres)		Sg Ft		Acres	
				Existing Rooftop Impervious Coverage		0		0.00	
				Existing Non-Rooftop Impervious Coverage		0		0.00	
				Proposed Rooftop Impervious Coverage		14733		0.34	
				Proposed Non-Rooftop Impervious Coverage		24102		0.55	
				Credits		Acres		Square Feet	
				Porous Pavement		0.00		0	
				Tree Planting		0.07		3,049	
				Downspout Disconnection		0.00		0	
Pre-Project Runoff Volume (cu ft)		0		Cu Ft.					
Project-Related Runoff Volume Increase w/o credits (cu ft)		682		Cu Ft.					
				Impervious Area Disconnection		0.00		0	
				Green Roof		0.00		0	
				Stream Buffer		0.00		0	
				Vegetated Swales		0.00		0	
Project-Related Volume Increase with Credits (cu ft)		644		Cu Ft.					
				Subtotal		0.07		3,049	
				Subtotal Runoff Volume Reduction Credits		38		Cu Ft.	
				(Step 9) Impervious Volume Reduction Credits		Volume (cubic feet)			
				Rain Barrels/Cisterns		0		Cu Ft.	
				Soil Quality		0		Cu Ft.	
				Subtotal Runoff Volume Reduction		0		Cu Ft.	
				Total Runoff Volume Reduction Credits		38		Cu Ft.	

BIO-RETENTION PLANTER TO BE USED FOR THE REMAINING VOLUME REQUIREMENT (SEE PLANTER SIZING CALCULATIONS ABOVE)

DATE SIGNED: THESE DRAWINGS ARE NOT CONSIDERED FINAL UNTIL THE ENGINEER'S SEAL BELOW HAS BEEN SIGNED AND DATED.



DESIGNED BY: RT
 DRAWN BY: RT
 CHECKED BY: SG
 SCALE: 1" = 40'

CECWEST.COM
 Project Planning = Civil Engineering = Landscape Architecture
 Sacramento Office
 2120 20th Street, Suite Three
 Sacramento, CA 95818
 (916) 455-2026

DAVIS
 PALISADES, LLC
 4630 FERMI PLACE
 STORMWATER QUALITY PLAN
 CALIFORNIA

SHEET 5 OF 5
 DATE: 03/10/2026
 JOB NO: 2094.00.04

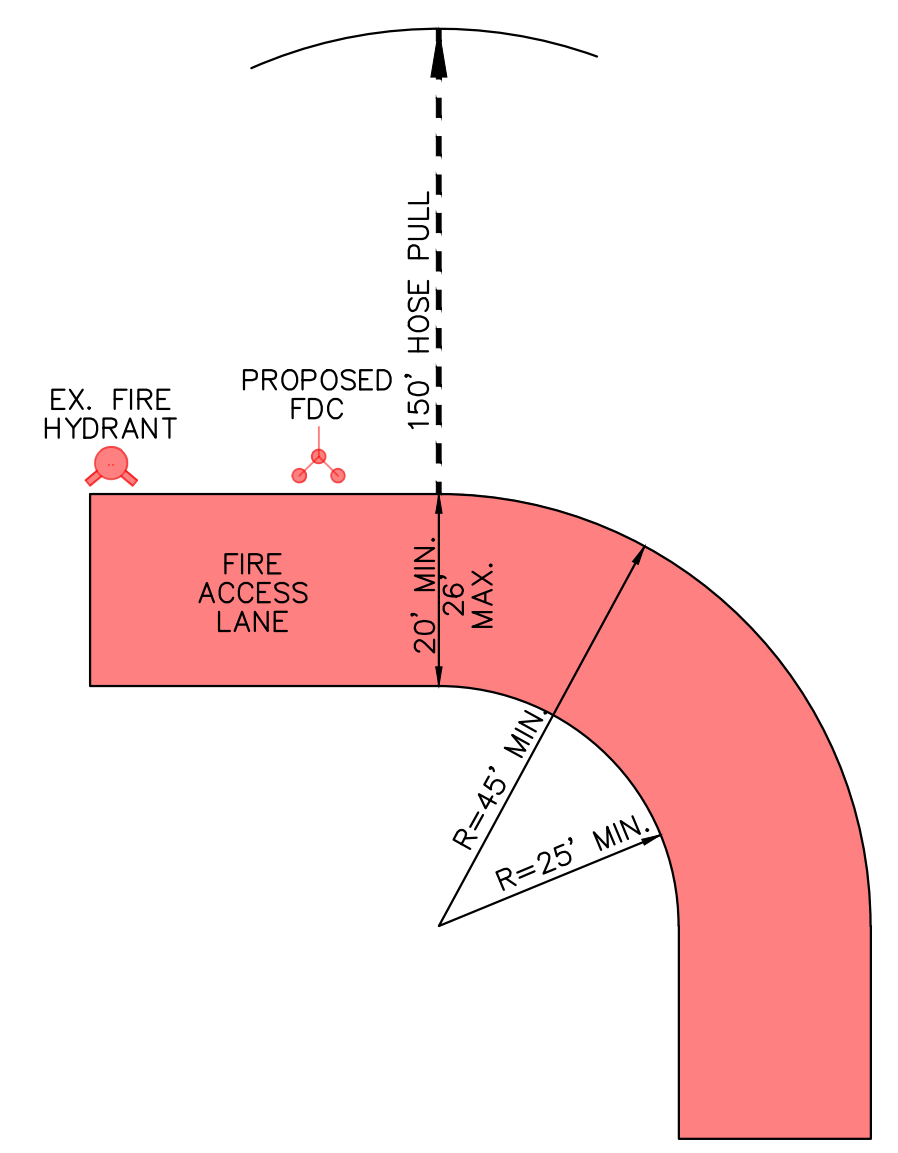
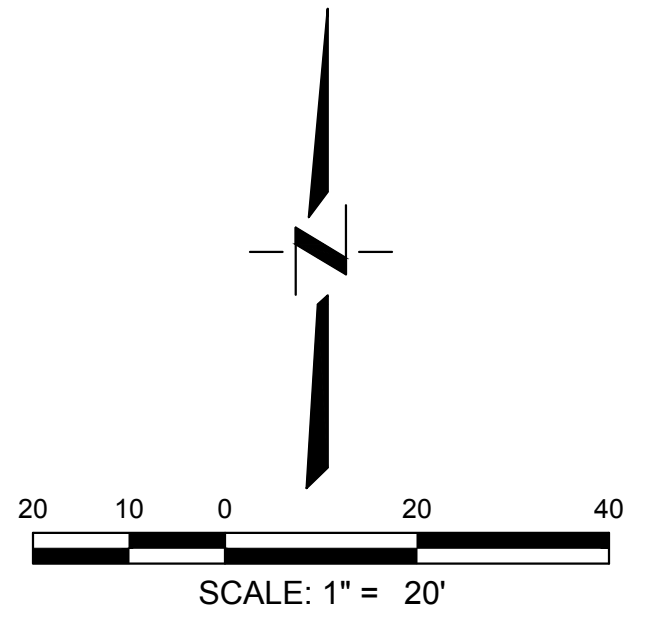

FIRE ACCESS LEGEND

DATE SIGNED:
 THESE DRAWINGS ARE NOT
 CONSIDERED FINAL UNTIL THE
 ENGINEER'S SEAL BELOW HAS
 BEEN SIGNED AND DATED.



DESIGNED BY	RT
DRAWN BY	RT
CHECKED BY	SG
SCALE	1" = 20'

NO.	DATE	REVISIONS	BY	APPD.

CECWEST.COM
 Project Planning • Civil Engineering • Landscape Architecture
 Davis Office
 2840 Spafford Street, Suite 110
 Davis, CA 95618
 (530) 758-2026
 Sacramento Office
 2120 20th Street, Suite Three
 Sacramento, CA 95818
 (916) 455-2026

PALISADES, LLC
4630 FERMI PLACE
PRELIMINARY FIRE ACCESS PLAN
 CALIFORNIA

DAVIS

SHEET
4
 OF
5

DATE: 03/10/2026
 JOB NO: 2094.00.04

S:\Projects\2009\2094 - 4630 Fermi Place, Davis\AutoCAD\2094-00-04-DD\SHEETS\2094-00-04-C4-FIRE.dwg - C4_3/10/2026 - 10:24AM Plotted by: Robb

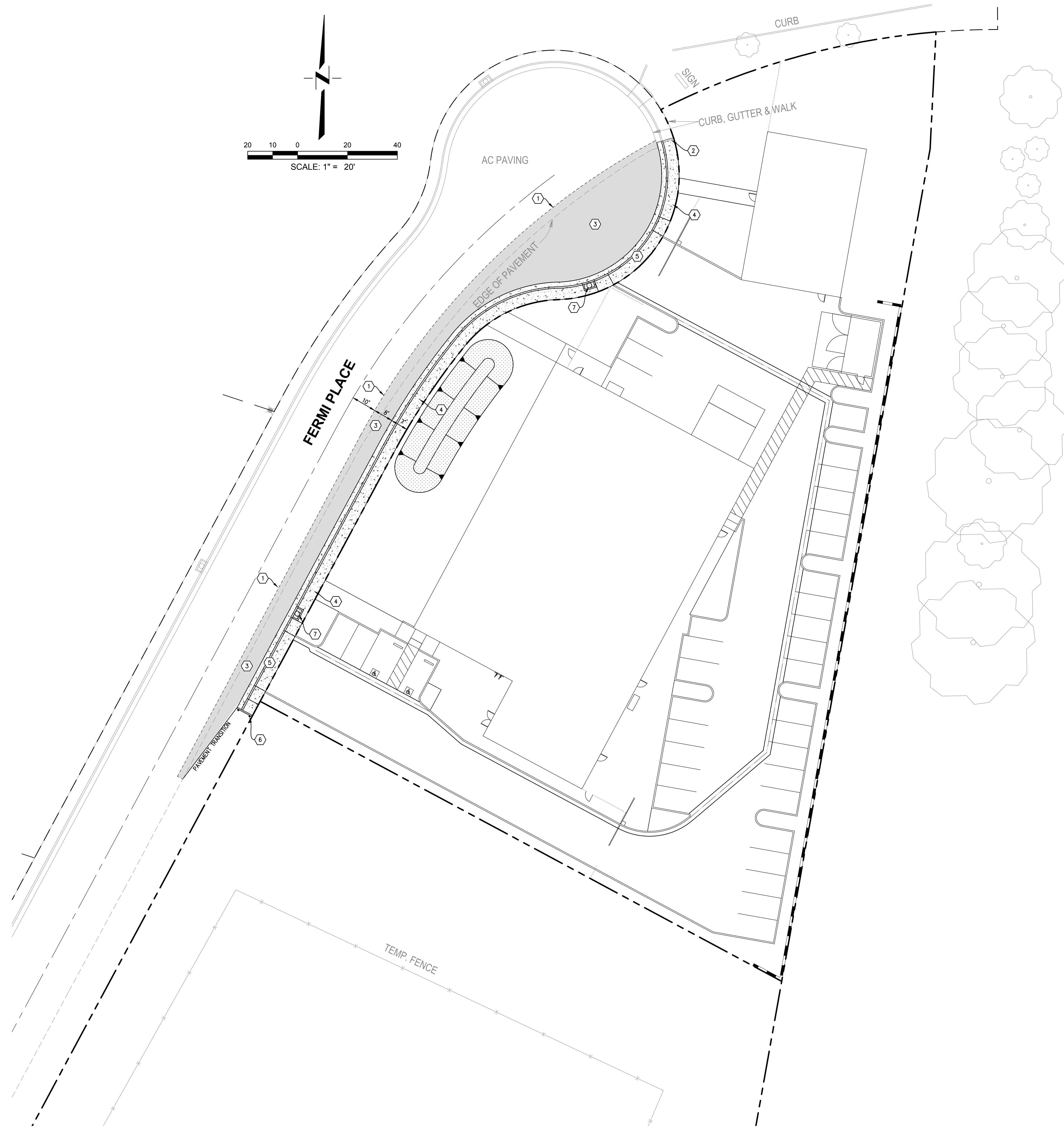
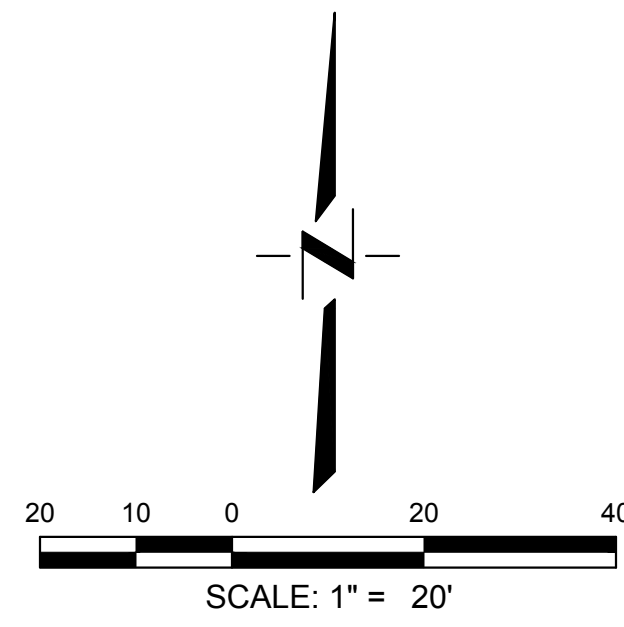

GRADING KEYNOTES:

- ① SAWCUT AND REMOVE EDGE OF EXISTING ASPHALT ROADWAY AS SHOWN.
- ② REMOVE EXISTING PEDESTRIAN BARRICADE.
- ③ PLACE ASPHALT PAVEMENT WIDENING AS SHOWN (4" AC/14" AB). MAINTAIN 1.5% MINIMUM AND 4.0 MAXIMUM CROSS SLOPES ON WIDENING.
- ④ INSTALL VERTICAL CURB, GUTTER AND 4.5' WIDE SIDEWALK PER CITY OF DAVIS STANDARD DRAWING 301-1.
- ⑤ INSTALL STANDARD HEAVY TYPE 1 DRIVEWAY PER CITY OF DAVIS STANDARD DRAWING 301-4.
- ⑥ INSTALL PEDESTRIAN BARRICADE PER CITY OF DAVIS STANDARD DRAWING 301-6.
- ⑦ INSTALL DROP INLET PER CITY OF DAVIS STANDARD DRAWING 401-1.

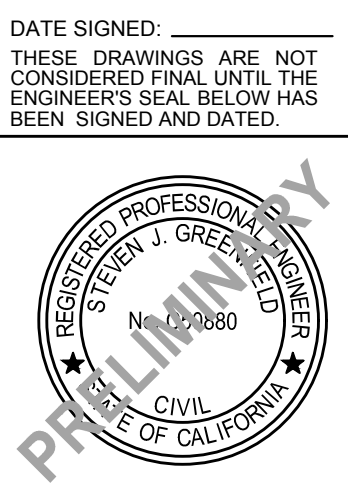

DATE SIGNED: _____
 THESE DRAWINGS ARE NOT
 CONSIDERED FINAL UNTIL THE
 ENGINEER'S SEAL BELOW HAS
 BEEN SIGNED AND DATED.

PALISADES, LLC
4630 FERMI PLACE

PRELIMINARY OFFSITE ROAD PLAN
 DAVIS CALIFORNIA

SHEET
5
 OF
5
 DATE: 03/10/2026
 JOB NO: 2094.00.04

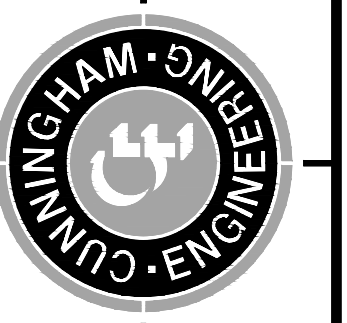

CECWEST.COM
 Project Planning - Civil Engineering - Landscape Architecture
 Sacramento Office
 2120 20th Street, Suite Three
 Sacramento, CA 95818
 (916) 455-2026

Davis Office
 2840 Spafford Street, Suite 110
 Davis, CA 95618
 (530) 758-2026

NO.	DATE	REVISIONS	BY	APPD.	DESIGNED BY	RT	DRAWN BY	RT	CHECKED BY	SG	SCALE
											1" = 20'